

INSTALLATION INSTRUCTIONS

4" ROUND SIDE BAR Part#81520.31

02-C Dodge Ram Quad Cab

PARTS LIST

- | | |
|--|--------------------------|
| (2) SIDE TUBES WITH STEPS | (8) ½" FLAT WASHER (BIG) |
| (2) FRONT MOUNT BRACKETS | (8) ½" LOCK WASHER |
| (2) REAR MOUNT BRACKETS | (6) 3/8" FLAT WASHERS |
| (2) FRONT BRACE BRACKETS (02-05 1500 SERIES) | (4) 3/8" HEX NUTS |
| (2) FRONT BRACE BRACKETS (02-05 2500/3500 SERIES) | (4) 3/8" LOCK WASHERS |
| (2) FRONT BRACE BRACKETS (06 1500/2500/3500 SERIES, longest one) | |
| (4) M12 – 1.75 x 120mm HEX HEAD BOLT | (4) ½" FLAT WASHER |
| (4) ½" – 13 x 2" HEX HEAD BOLT | (4) 1/2" HEX NUTS |
| (2) 3/8" x 1 ¼" HEX HEAD BOLT | |
| (2) 3/8" x 1 ¼" HEX HEAD BOLT WITH METAL STRAP | |
| (4) ½" x 1.88 x 3/16" SPACER | |

PROCEDURE

1. Begin installation by working on driver side of the vehicle (refer to Figures 1. 1- 1.5)
2. From underneath truck, loosen and remove body mount bolts that run upward through mounts into floorboard. Attach and secure Front Mount Bracket to underside of vehicles front body mount (see Figure 1.3), re-using isolator, but replacing factory bolt with (1) M12 – 1.75 x 120mm bolt, (1) ½" split lock washer, and (1) ½" flat washer. Also, Place (1) ½" x 1.88 x 3/16" spacer between the Mount Bracket and the isolator. Hand Tighten.
3. Attach and secure Rear Mount Bracket to underside of vehicles rear body mount in same manner as the front.

For 02-05 1500 Series Ram

4. Discard 2500/3500 Front Brace Bracket (see Figure 1.2). Place (1) 3/8" x 1 ½" bolt with welded strap and (1) ½" flat washer through cut out in frame rail (see Figure 1.4). Line up slot on the long arm of the Brace Bracket with this bolt and secure using (1) 3/8" flat washer and (1) 3/8"hex nut,(1) lock washer Hand Tighten.

Note: The slot on the short arm of the Brace Bracket should now align with the Mount Bracket slot.

For 02-05 2500 and 3500 Series Ram

4. Discard 1500 Front Brace Bracket (see Figure 1.1). Attach Front Brace Bracket to side of Front Mount Bracket using (1) 3/8" x 1 ¼" bolt, (2) 3/8" flat washers, and (1) 3/8" hex nut ,(1) lock washer (see Figure 1.5). Place (1) 3/8" x 1 ½" bolt with welded strap and (1) ½" flat washer through cut out in frame rail. Line up slot on the long arm of the Brace Bracket with this bolt and secure using (1) 3/8" flat washer and (1) 3/8" lock nut,(1) lock washer. Hand tighten.

For 06 1500/2500/3500 Series Ram

4. Using 06 1500/2500/3500 Brace Bracket (See Figure 1.6). (1). Attach Front Brace Bracket to side of Front Mount Bracket using (1) 3/8" x 1 ¼" bolt, (2) 3/8" flat washers, and (1) 3/8" hex nut ,(1) lock washer (see Figure 1.5). Place (1) 3/8" x 1 ½" bolt with welded strap and (1) ½" flat washer through cut out in frame rail. Line up slot on the long arm of the Brace Bracket with this bolt and secure using (1) 3/8" flat washer and (1) 3/8" lock nut,(1) lock washer. Hand tighten.

5. Attach Side Tube to Front and Rear Brackets using (1) $\frac{1}{2}$ " - 13 x 2" bolt, (1) $\frac{1}{2}$ " split lock washer and (1) $\frac{1}{2}$ " flat washer for each bracket, and hand tighten. Torque M12 bolts first to 65 ft-lbs and then tighten all remaining fasteners to complete the driver-side assembly.
6. Repeat process for passenger side of vehicle to complete installation.



Figure 1.1 – 02-05 1500 Front Brace



Figure 1.2 – 02-05 2500/3500 Front Brace



Figure 1.6- 06 1500/2500/3500 Front Brace

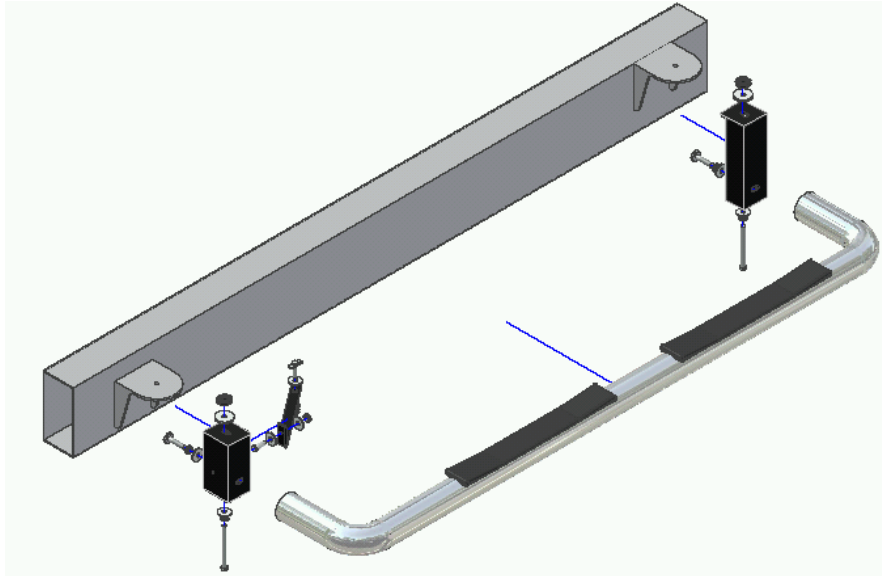

Figure 1.3 –Driver-Side Front Assembly View (2500/3500 Series set-up shown)

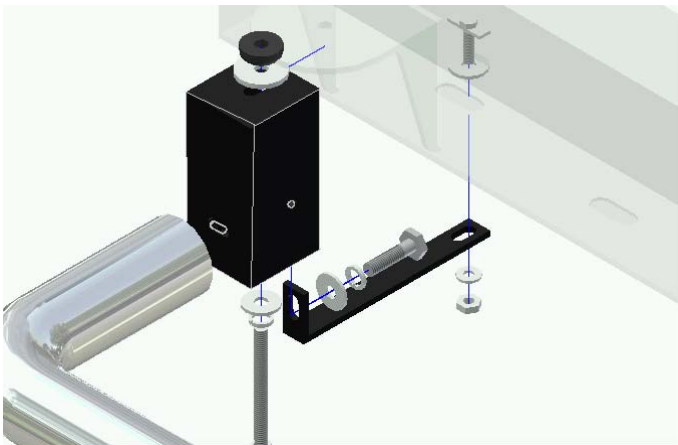

Figure 1.4 – 1500 Front Mount Assembly

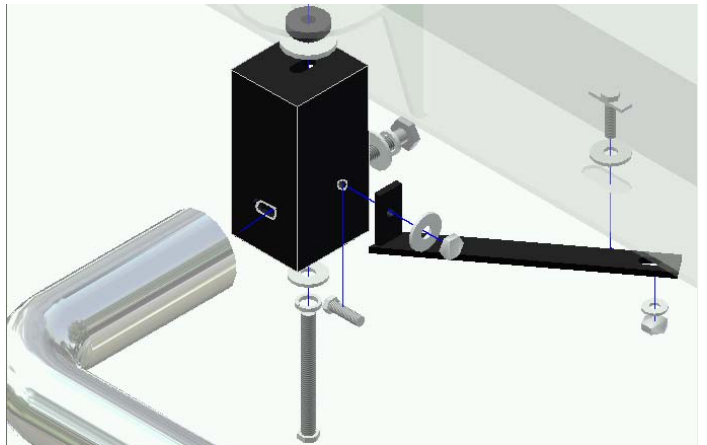

Figure 1.5 – 2500/3500 Front Mount Assembly